



CORKBEE

[info@corkbee.com](mailto:info@corkbee.com)

[www.corkbee.com](http://www.corkbee.com)



## CORKBEE

Polish brand focused on good design,  
high quality and sustainability.  
Polska marka stawiająca na dobry design,  
wysoką jakość i zrównoważony rozwój.

## CORKWALL

Collection of 3D wall panels made of natural cork.  
Kolekcja paneli ściennych 3D  
wykonanych z naturalnego korka.



Cork is renewable, recyclable and biodegradable.  
Korek jest odnawialny, biodegradowalny,  
nadaje się do recyklingu



Corkbee panels take care of the acoustics and  
microclimate of the interior.  
Panele Corkbee zadbają o akustykę  
i mikroklimat wnętrza.



Environmentally friendly product  
Produkt przyjazny środowisku



Corkbee panels have many arrangement possibilities,  
creating unique final effects on the wall.  
Panele Corkbee mają wiele możliwości ułożenia,  
tworząc unikalne efekty końcowe na ścianie.



Available in 11 standard colors  
with the possibility of custom colors  
Dostępne w 11 standardowych kolorach  
z możliwością wykonania kolorów na zamówienie



The panels are light.  
They can also be mounted on the ceiling.  
Panele są lekkie.  
Mogą być montowane również na suficie.



The panels are easy to install.  
Panele są łatwe w montażu



Antistatic material.  
Materiał antystatyczny.



Corkbee panels can be fire-retardant impregnated  
and receive a certificate C-s2, d0 (EN 13501-1 :2018)  
Panele Corkbee mogą zostać zaimpregnowane przeciwogniowo  
z certyfikatem C-s2,d0 (EN 13501-1 :2018)

POSSIBILITIES OF INSTALLATION (EXAMPLES)  
 PRZYKŁADOWE MOŻLIWOŚCI MONTAŻU

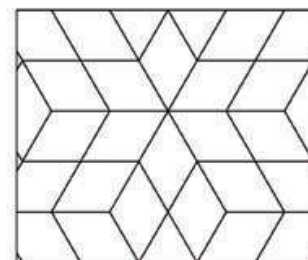
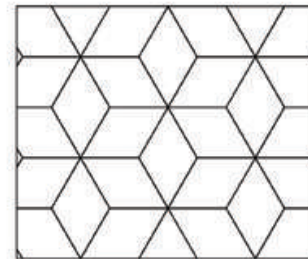
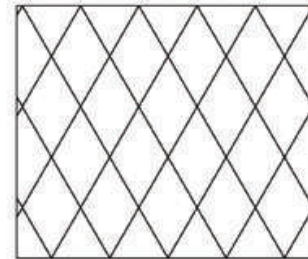
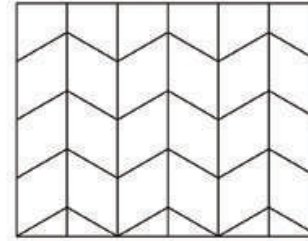

# STRIPE

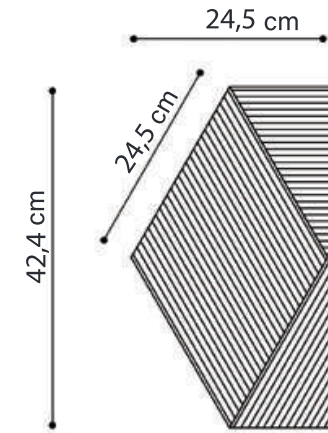

**CORKWALL PANELS:** Agglomerated cork produced using compression moulding technology  
 PANELE CORKWALL: Korek aglomerowany formowany pod ciśnieniem

**PACKING:** 3 pieces  
 PAKOWANIE: 3 sztuki

**PANELS IN 1 M2:** 19  
 LICZBA PANELI W 1 M2: 19

**WEIGHT:** 230 g Natural/ 250 g Colour  
 WAGA: 230 g Natural / 250 g Kolor

**THICKNESS:** 5 mm - 10 mm  
 GRUBOŚĆ: 5 mm - 10 mm

COLOURS  
 KOLORY



IVORY



NATURAL

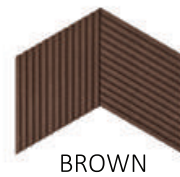

BROWN

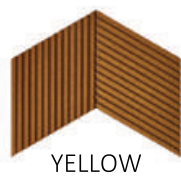

YELLOW



GREY

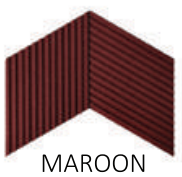

MAROON

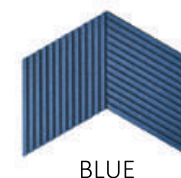

BLUE



DEEP BLUE



DARK GREEN



GREEN



BLACK

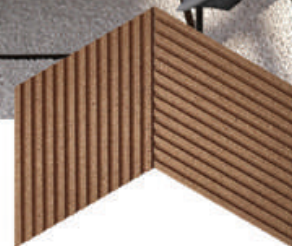

NATURAL





NATURAL

POSSIBILITIES OF INSTALLATION (EXAMPLES)  
PRZYKŁADOWE MOŻLIWOŚCI MONTAŻU

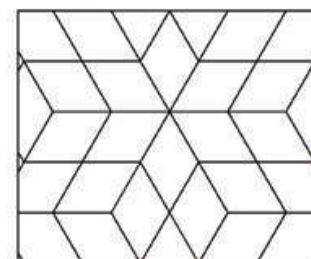
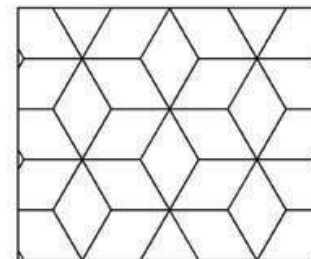
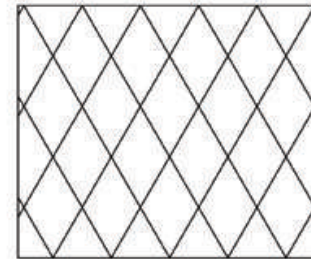
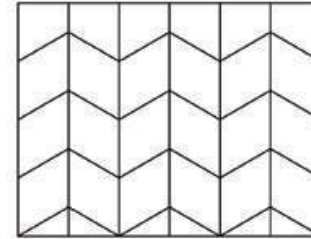

LINE

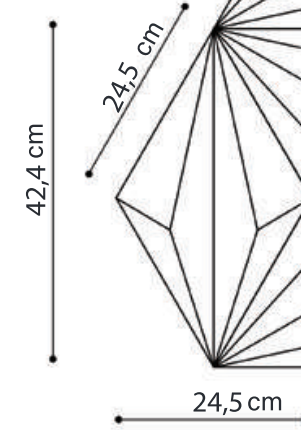

**CORKWALL PANELS:** Agglomerated cork produced using compression moulding technology

PANELE CORKWALL: Korek aglomerowany formowany pod ciśnieniem

**PACKING:** 3 pieces

PAKOWANIE: 3 sztuki

**PANELS IN 1 M2:** 19

LICZBA PANELI W 1 M2: 19

**WEIGHT:** 230 g Natural/ 250 g Colour

WAGA: 230 g Natural/ 250 g Kolor

**THICKNESS:** 5 mm - 30 mm

GRUBOŚĆ: 5 mm - 30 mm

COLOURS  
KOLORY



IVORY



NATURAL



BROWN



YELLOW



GREY

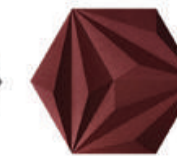

MAROON



BLUE

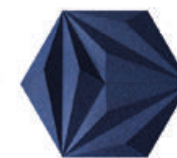

DEEP BLUE

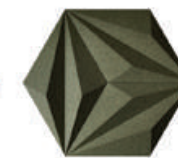

DARK GREEN



GREEN



BLACK

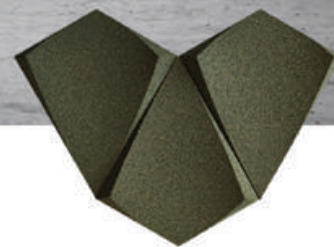

DARK GREEN

POSSIBILITIES OF INSTALLATION (EXAMPLES)  
PRZYKŁADOWE MOŻLIWOŚCI MONTAŻU

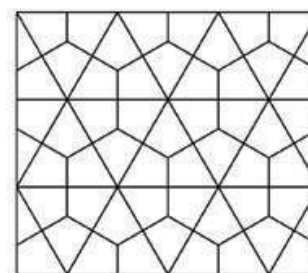
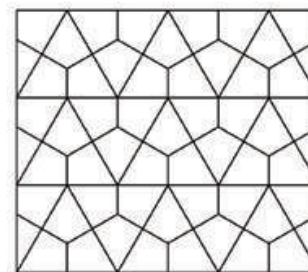
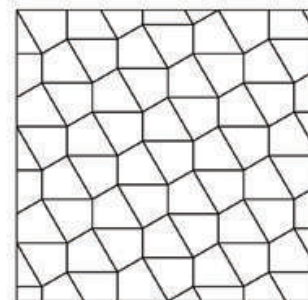
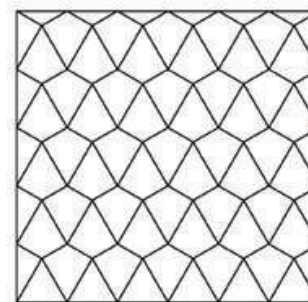

**CORKWALL PANELS:** Agglomerated cork produced using compression moulding technology

PANELE CORKWALL: Korek aglomerowany formowany pod ciśnieniem

**PACKING:** 6 pieces  
PAKOWANIE: 6 sztuki

**PANELS IN 1 M2:** 40  
LICZBA PANELI W 1 M2: 40

**WEIGHT:**  
150 g Natural/ 180 g Color  
WAGA: 150 g Natural/ 180 g Kolor

**THICKNESS:**  
20 mm - 30 mm  
GRUBOŚĆ: 20 mm - 30 mm

# KITE

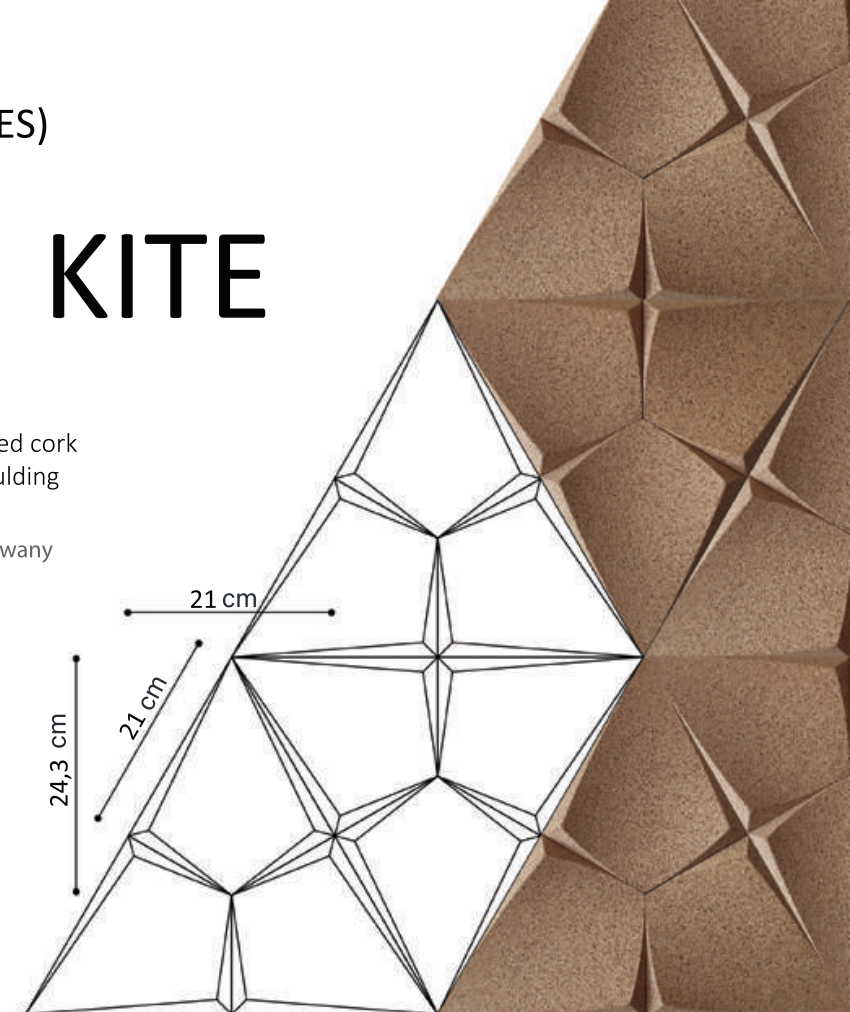

COLOURS  
KOLORY



IVORY

NATURAL

BROWN

YELLOW

GREY

MAROON

BLUE

DEEP BLUE

DARK GREEN

GREEN

BLACK



GREY

POSSIBILITIES OF INSTALLATION (EXAMPLES)  
 PRZYKŁADOWE MOŻLIWOŚCI MONTAŻU

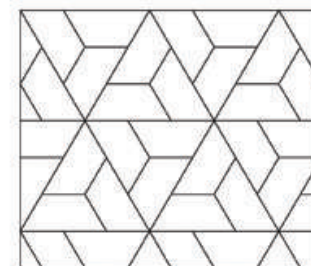
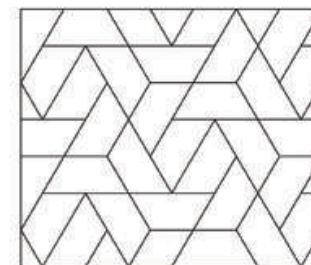
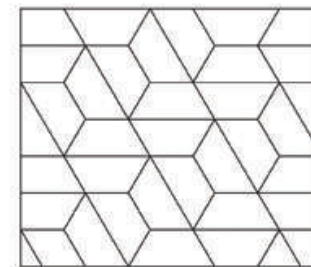
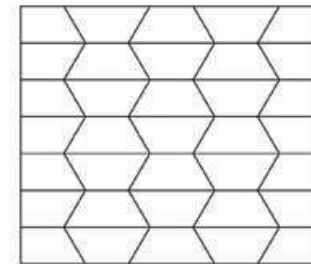

# WEAVE

**CORKWALL PANELS:** Agglomerated cork produced using compression moulding technology  
 PANELE CORKWALL: Korek aglomerowany formowany pod ciśnieniem

**PACKING:** 9 pieces  
 PAKOWANIE: 9 sztuki

**PANELS IN 1 M2:** 25  
 LICZBA PANELI W 1 M2: 25

**WEIGHT:** 150 g Natural/ 180 g Colour  
 WAGA: 150 g Natural/ 180 g Kolor

**THICKNESS:** 5 mm - 15 mm  
 GRUBOŚĆ: 5 mm - 15 mm

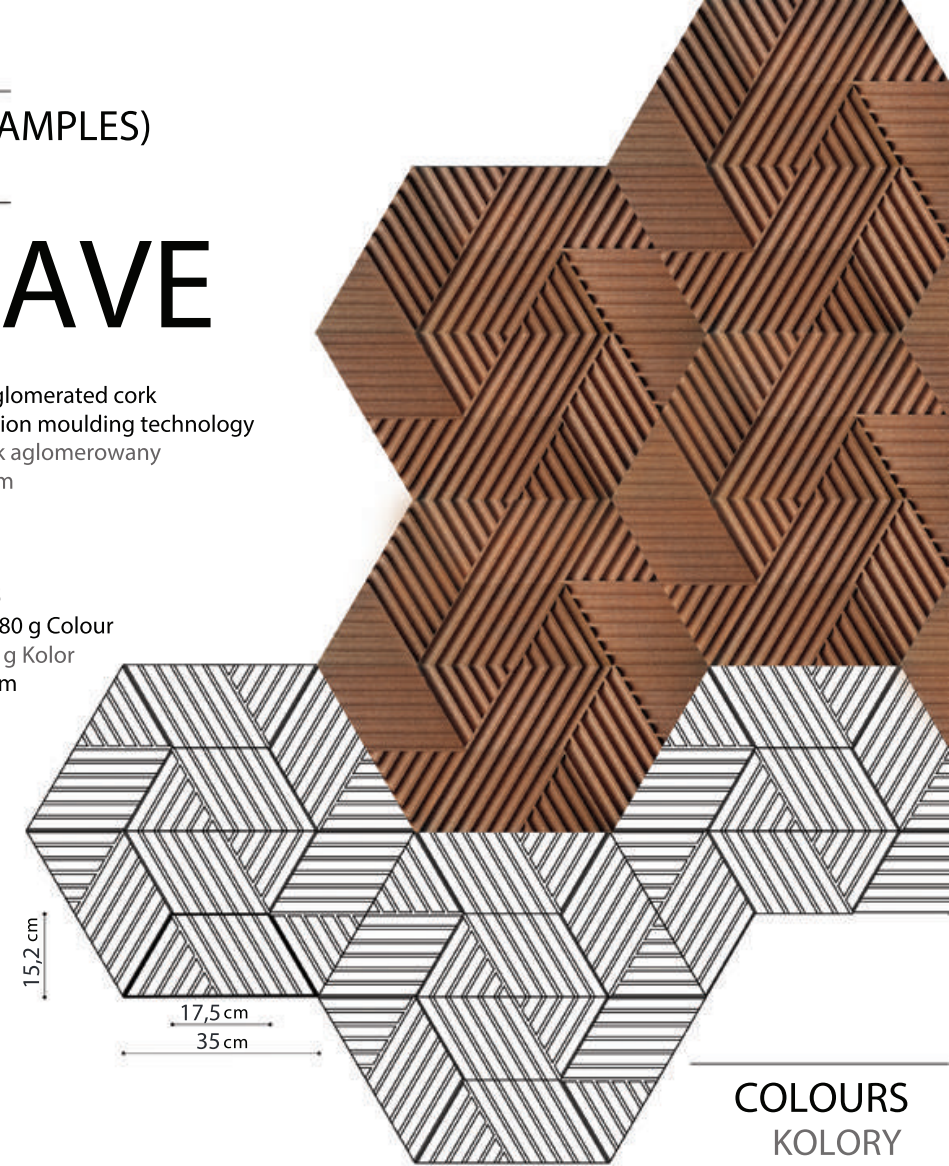

COLOURS  
 KOLORY



IVORY



NATURAL



BROWN



YELLOW



GREY



MAROON



BLUE



DEEP BLUE



DARK GREN



GREEN



BLACK

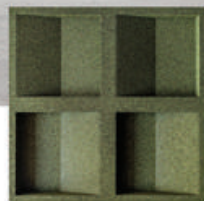

GREEN

POSSIBILITIES OF INSTALLATION (EXAMPLES)  
 PRZYKŁADOWE MOŻLIWOŚCI MONTAŻU

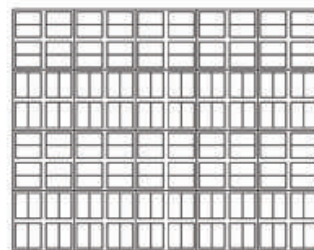
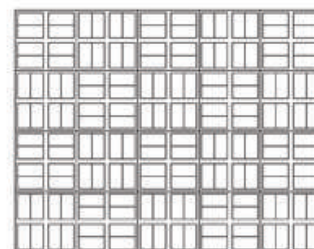
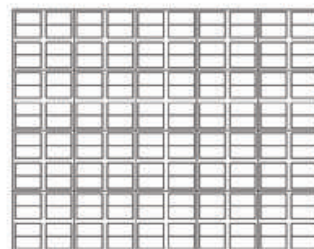

# CONCAVE

**CORKWALL PANELS:** Agglomerated cork produced using compression moulding technology  
 PANELE CORKWALL: Korek aglomerowany formowany pod ciśnieniem  
**PACKING:** 4 pieces  
 PAKOWANIE: 4 sztuki  
**PANELS IN 1 M2:** 16  
 LICZBA PANELI W 1 M2: 16  
**WEIGHT:** 300 g Natural/ 340 g Colour  
 WAGA: 300 g Natural/ 340 g Kolor  
**THICKNESS:** 25 mm  
 GRUBOŚĆ: 25 mm

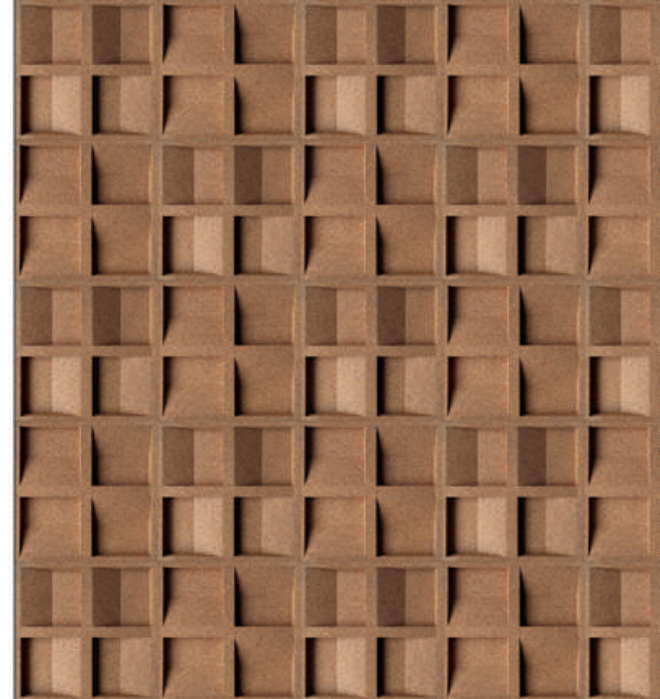

25 cm

25 cm

COLOURS  
 KOLORY



IVORY



NATURAL



BROWN



YELLOW



GREY



MAROON



BLUE



DEEP BLUE



DARK GREN



GREEN



BLACK

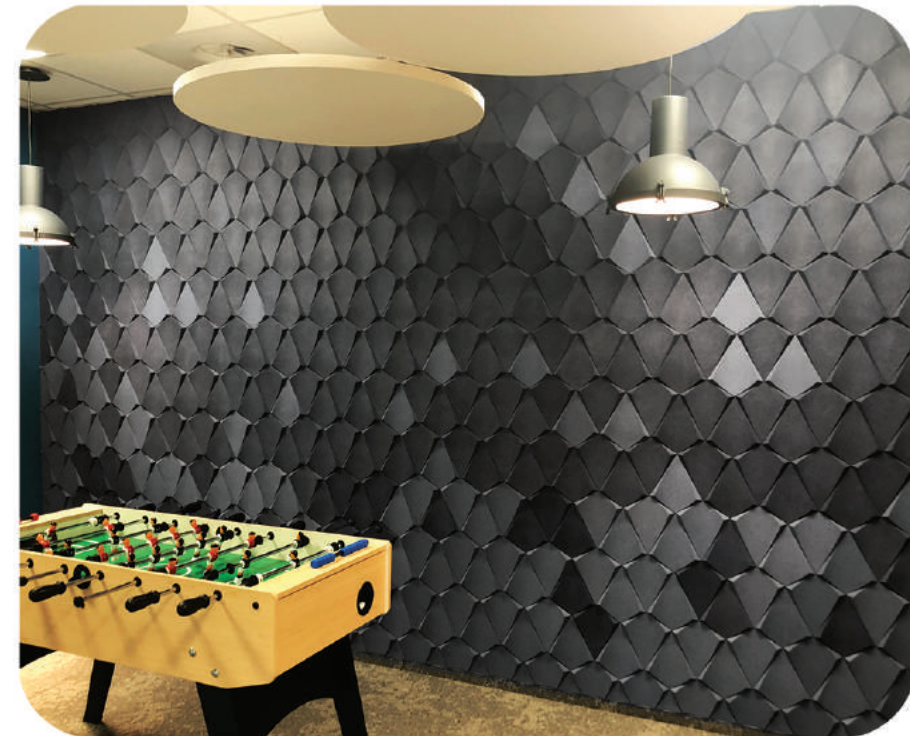
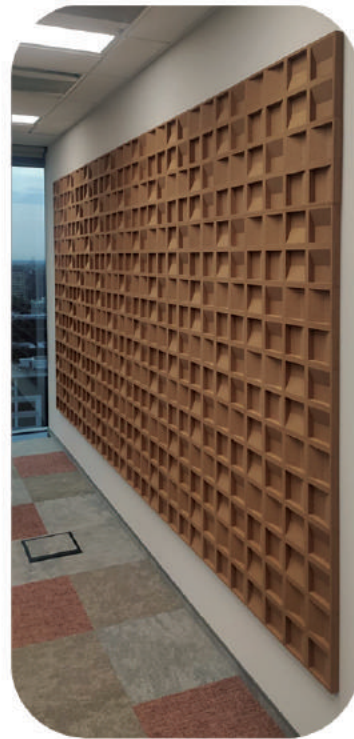
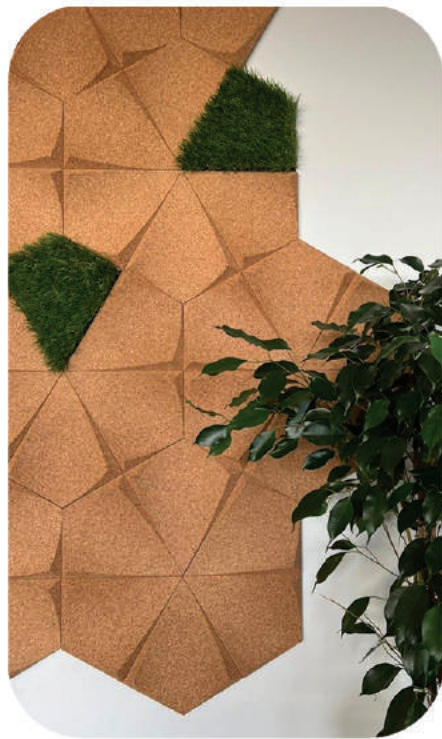



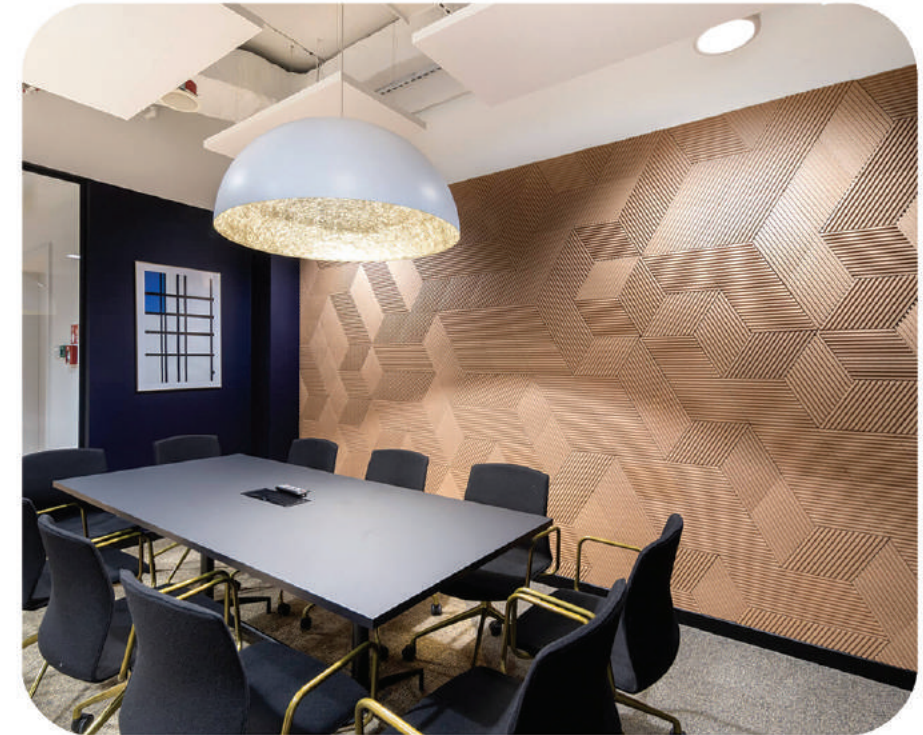
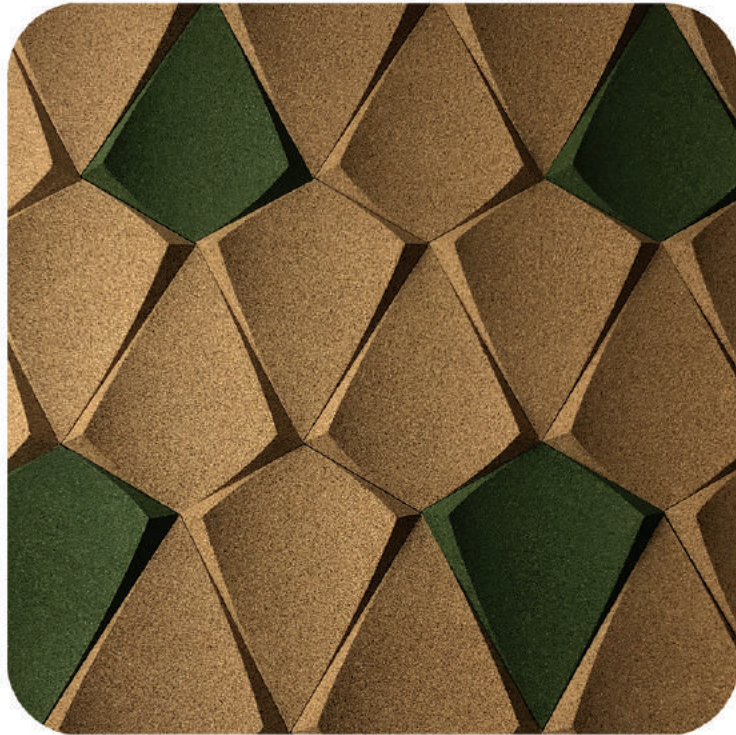
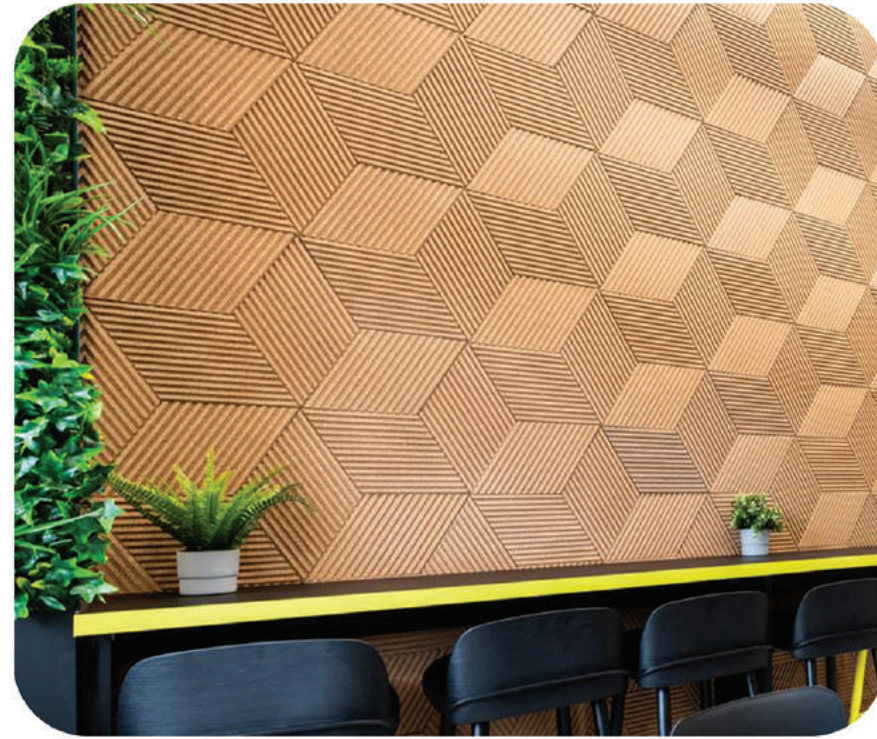

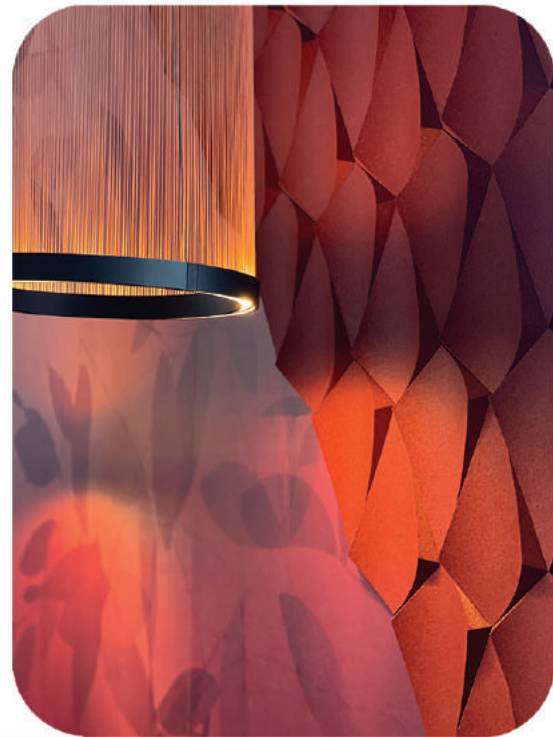
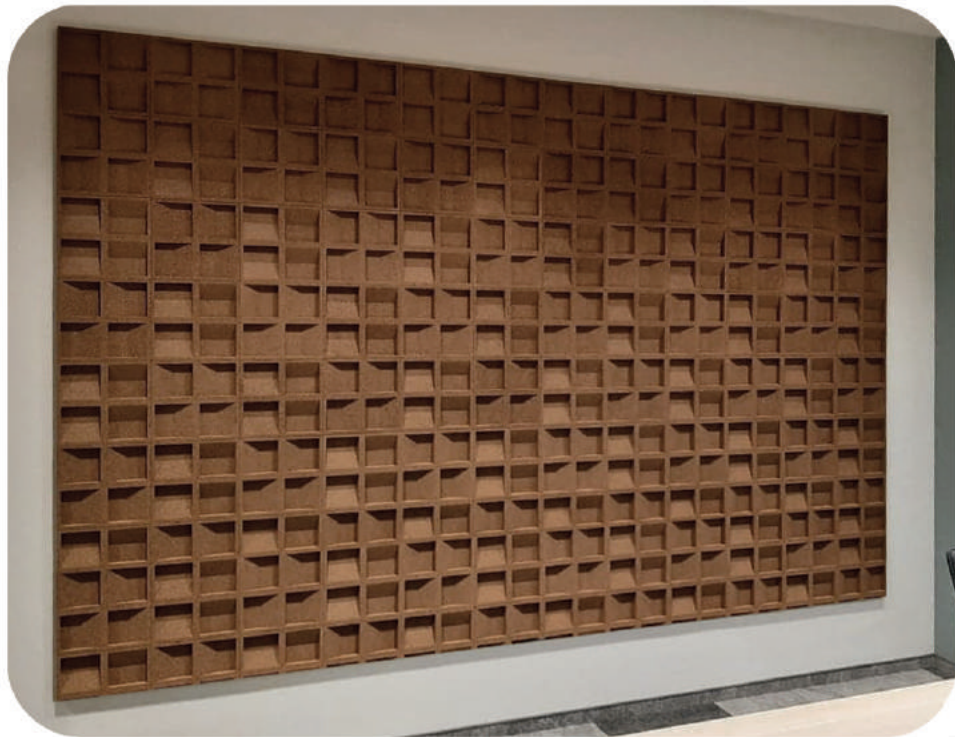



CORKBEE

[info@corkbee.com](mailto:info@corkbee.com)

[www.corkbee.com](http://www.corkbee.com)

# Measurement of sound absorption in a reverberation chamber according to EN ISO 354:2005

Determination of the sound absorption coefficient according to EN ISO 11654:1999

2023-03-28

**Principal:** CORKBEE  
**Manufacturer:** CORKBEE  
**Research laboratory:** CTO S.A. Environmental Research Laboratories Team. Vibroacoustic Testing Laboratory  
**Sample designation:** LA1953  
**Sample description:** three-dimensional wall panels

**Sample area:** 10,98 m<sup>2</sup>      **Reverberation chamber, with sample:** Reverberation chamber, empty:  
**Volume of the reverberation chamber:** 200,00 m<sup>3</sup>      **Temperature:** 19,0 °C      **Temperature:** 19,0 °C  
**Relative humidity:** 53,4 %      **Relative humidity:** 53,4 %  
**Atmospheric pressure:** 99,7 kPa      **Atmospheric pressure:** 99,7 kPa

**Environmental conditions:**

f [Hz].	T <sub>1</sub> [s]	T <sub>2</sub> [s]	A <sub>T</sub> [m <sup>2</sup> ]	α <sub>S</sub>	α <sub>P</sub>
100	5,5	5,4	0,1	0,01	
125	6,0	5,9	0,1	0,01	0,00
160	5,3	4,9	0,4	0,04	
200	5,3	5,0	0,4	0,04	
250	5,6	5,1	0,6	0,06	0,05
315	5,4	4,9	0,7	0,06	
400	5,5	4,8	0,9	0,08	
500	5,6	4,5	1,5	0,13	0,15
630	5,2	4,0	2,0	0,18	
800	4,9	3,4	2,8	0,26	
1000	4,6	3,2	3,0	0,28	0,25
1250	4,4	3,2	2,7	0,24	
1600	4,1	3,1	2,5	0,23	
2000	3,8	3,0	2,3	0,21	0,20
2500	3,4	2,7	2,4	0,22	
3150	2,8	2,3	2,6	0,24	
4000	2,3	1,9	3,0	0,27	0,30
5000	1,9	1,6	3,5	0,32	

Indications:  
*f* - frequency, in thirds bands [Hz].  
*T*<sub>1</sub> - reverberation time of the reverberation chamber, empty [s].  
*T*<sub>2</sub> - reverberation time of the reverberation chamber, with sample [s].  
α<sub>S</sub> - sound absorption coefficient  
α<sub>P</sub> - practical sound absorption coefficient  
A<sub>T</sub> - equivalent sound absorption area of the test sample [m<sup>2</sup>]

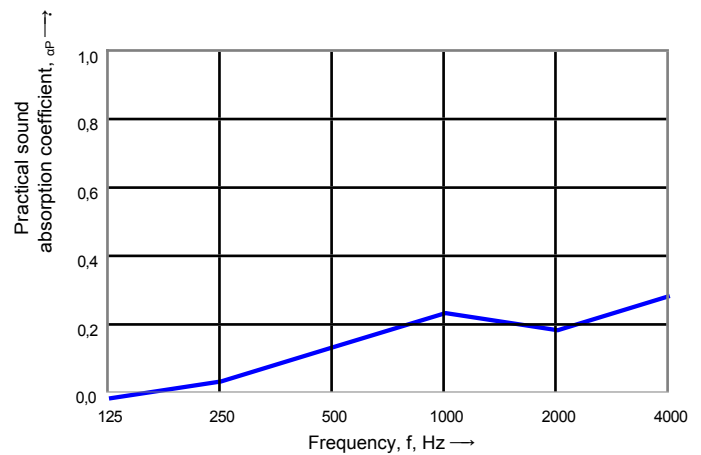
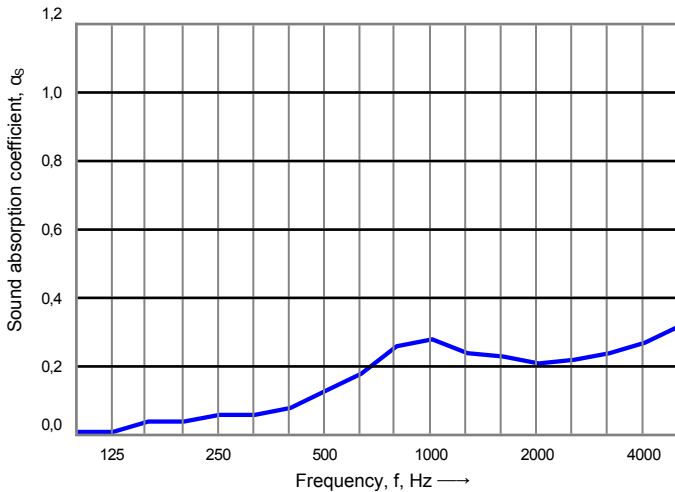

Sound absorption index and class in accordance with EN ISO 11654:1999

**α<sub>w</sub> = 0,20**

**Sound absorption class: E**

**Study no:** B195301  
**Date of survey:** 2023-03-28

**Caption:** Piotr Jakubowski

---

## **CLASSIFICATION OF REACTION TO FIRE ACCORDANCE WITH EN 13501-1:2018**

---

### **1. Introduction**

This classification report defines the classification assigned to Corkwall cork panels in accordance with the procedures in EN 13501-1:2018.

**Sponsor:** BEEDESIGN PATRYK SKOLIMOWSKI  
Powstańców Śląskich 89D/171  
01-355 Warsaw, Poland

**Prepared by:** SYCHTA LABORATORIUM Sp. J.  
Laboratorium Badań Palności Materiałów  
ul. Ofiar Stutthofu 90  
72-010 Police, Poland

**Notified Body No:** -

**Product name:** Corkwall cork panels

**Classification report No:** SL/Z-223/EN13501/0306a/2023

**Date of issue:** 05.05.2023

This classification report consists of four pages and may only be used or reproduced in its entirety.

### **2. Details of classified product**

#### **2.1. General**

The product, Corkwall cork panels

THE CERTIFICATE APPLIES ONLY TO IMPREGNATED PANELS AND IS ONLY VALID WITH A STATEMENT ON PANEL IMPREGNATION OBTAINED FROM THE MANUFACTURER.

## 2.2. Product description

The product, Corkwall cork panels, is described below or is described in the reports provided in support of classification listed in 3.1

Natural cork milled on one side, diamond-shaped formats with dimensions of 240 mm and a shorter diagonal of 235 mm, coated with an impregnating agent. Total thickness of 10,6-11,4 mm and weight per unit area approx. 10,9 kg/m<sup>2</sup>.

## 3. Reports and results in support of this classification

### 3.1. Specific conditions

-

### 3.2. Reports

Name of Laboratory	Name of sponsor	Report ref. No.	Test method and date Field of application rules and date
Sychta Laboratorium	BEEDESIGN PATRYK SKOLIMOWSKI	SL/Z-223/PN13823/0305a/2023	PN-EN ISO 13823 PN-EN ISO 11925-2 27.03 and 28.04.2023

### 3.3. Results

Test method and test number	Parameter	No. Tests <sup>a</sup>	Results	
			Continuous parameter - mean (m)	Compliance with parameters
PN-EN 13823	FIGRA, W·s <sup>-1</sup>	3	144	(-)
	THR <sub>60s</sub> , MJ		67	(-)
	LFS < edge		(-)	Compliant
	SMOGRA, m <sup>3</sup> ·s <sup>-2</sup>		20	(-)
	TSP <sub>600s</sub> , m <sup>2</sup>		87	(-)
	Flaming particles or droplets, time s		144	Compliant
PN-EN ISO 11925-2 Exposure time 30 s	Flame spread > 150 mm in 60 s, mm	6	(-)	Compliant
	Ignition of paper		(-)	Compliant

<sup>a</sup> Not for extended application, (-): not applicable

THE CERTIFICATE APPLIES ONLY TO IMPREGNATED PANELS AND IS ONLY VALID WITH A STATEMENT ON PANEL IMPREGNATION OBTAINED FROM THE MANUFACTURER.

#### 4. Classification and field of application

##### 4.1. Reference of classification

This classification has been carried out in accordance with EN 13501-1:2018.

##### 4.2. Classification

The product, Corkwall cork panels, in relations to its reaction to fire behaviour is classified:

**C**

The additional classification in relations to smoke production is:

**s2**

The additional classification in relations to flaming droplets / particles is:

**d0**

The format of the reaction to fire classification for construction products excluding floorings and linear pipe thermal insulation products is:

Fire behaviour		Smoke production			Flaming droplets	
<b>C</b>	-	<b>s</b>	<b>2</b>	,	<b>d</b>	<b>0</b>

**Reaction to fire classification: C-s2,d0**

### 4.3. Field of application

This classification is valid for the following product parameters:

- varnished natural cork milled on one side
- diamond-shaped formats with dimensions of 240 mm and a shorter diagonal of 235 mm.
- total thickness of 10,6-11,4 mm
- weight per unit area approx. 10,9 kg/m<sup>2</sup>

The classification is valid for the following end use applications:

Cork panels glued with Bostik "Mamut" glue on a standard mineral substrate of class A2-s1,d0

### 5. Limitations

This classification document does not represent type approval or certification of the product.

*Signature of person  
undertaking classification:*

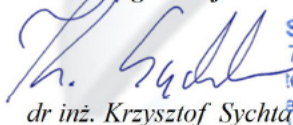
  
dr inż. Krzysztof Sychta

SYCHTA LABORATORIUM Sp. J.  
72-010 Police, ul. Ofiar Stutthofu 90  
tel./fax +48 91 4210 214, tel. 502078855  
e-mail: biuro@sychta.eu www.sychta.eu  
KRS 0000387681 REGON 321023120  
NIP 8513152392

*Signature of person  
authorising report:*

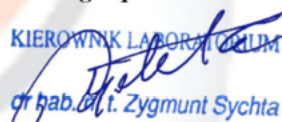
  
dr hab. inż. Zygmunt Sychta